



*Great sound
from Barcelona
since 1972*

www.amateaudio.com

User's manual ***Manual de usuario***

UB-L

Universal wall-bracket
Soporte pared universal

April 2023

- The UB-L is an optional accessory for wall mounting (horizontal orientation).
 ~ *El UB-L es un accesorio opcional para el colgado en pared (horizontal).*

- Locking screw (left)
 ~ *Tornillo para bloqueo (izquierda)*

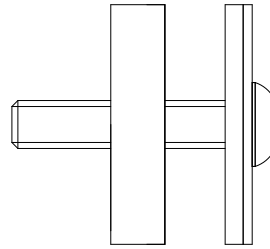

- Locking block (right)
 ~ *Cilindro para bloqueo (derecha)*

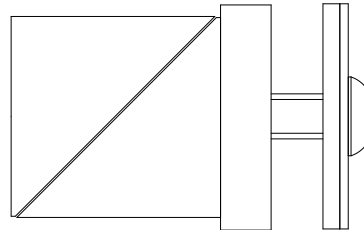

- Bracket (left piece)
 ~ *Soporte (pieza izquierda)*

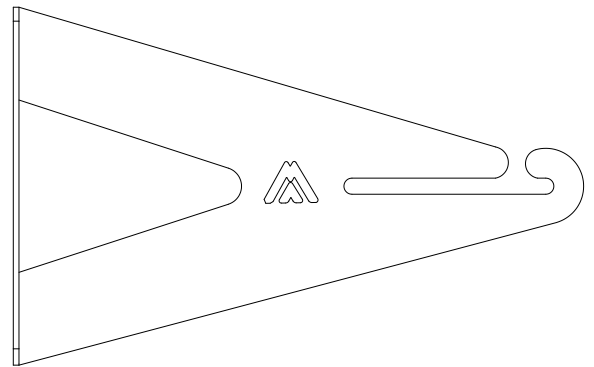
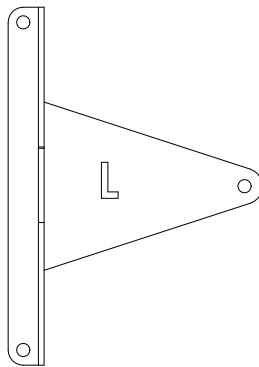

- Bracket (right piece)
 ~ *Soporte (pieza derecha)*

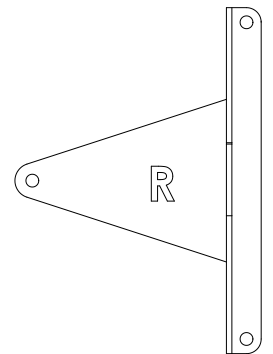
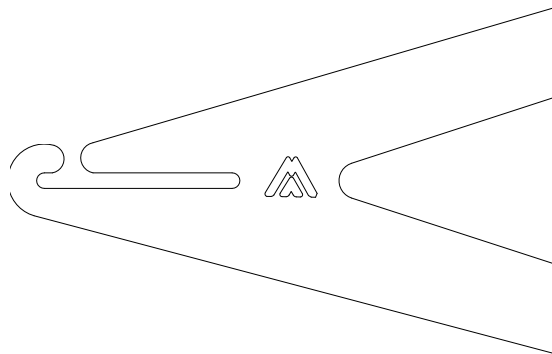

- DIN7505B 5x30 screw (x6)
 ~ *Tornillo DIN7505B 5x30 (x6)*

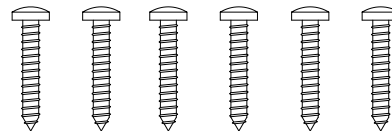

- Fischer plug S6 (x6)
 ~ *Taco Fischer S6 (x6)*

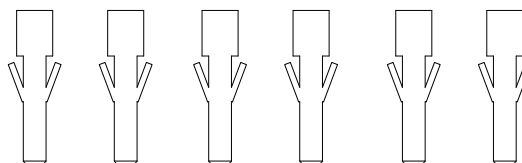

- Put the locking block (A) inside the 35-mm top hat's hole (except in JK12MA).
 ~ Coloque el cilindro (A) dentro del agujero del vaso de 35mm (menos en la JK12MA).

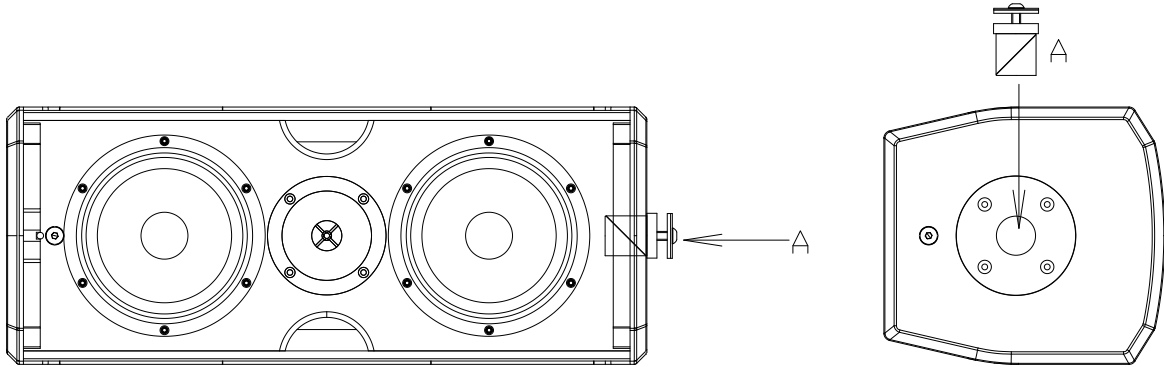

- For the JK12MA, remove the screw from the locking block and place it on the following M8 hole (only in JK12MA)
 ~ Para la JK12MA, desenrosque el cilindro de su eje y coloque el conjunto sobrante (tornillo y arandelas) en el punto indicado con una flecha (sólo para JK12MA)

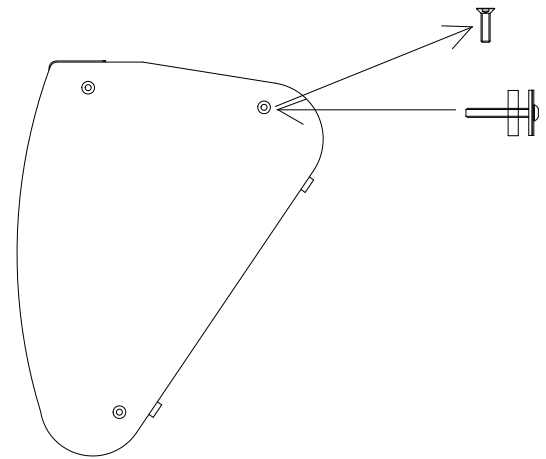
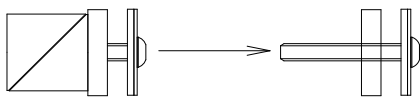

- Remove the top M8 screw. Put the new locking screw.
 ~ Quite el tornillo de M8 situado en la parte superior de la caja y coloque el tornillo para bloquear

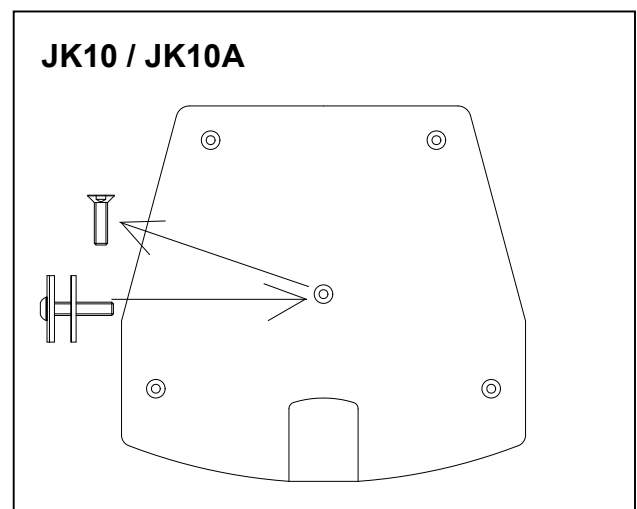
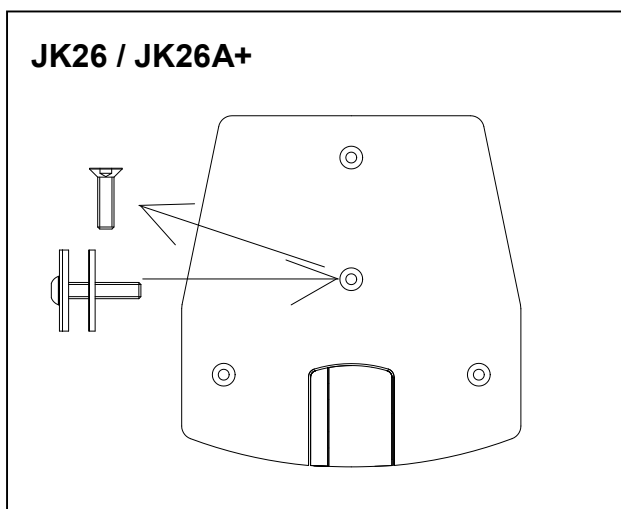

JK10MA

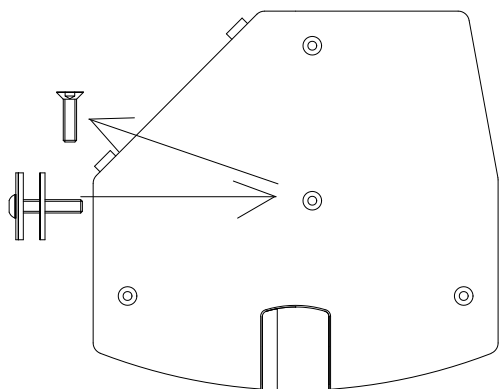

KEY10 / KEY10A

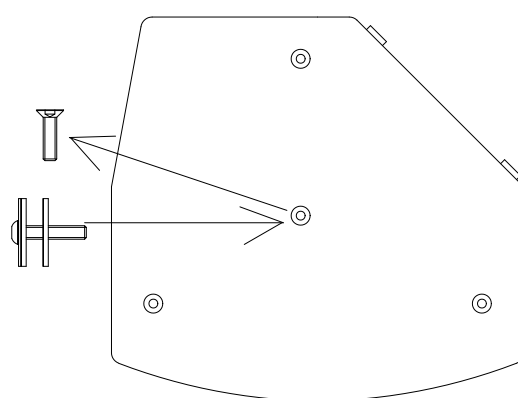

JK12 / JK12A

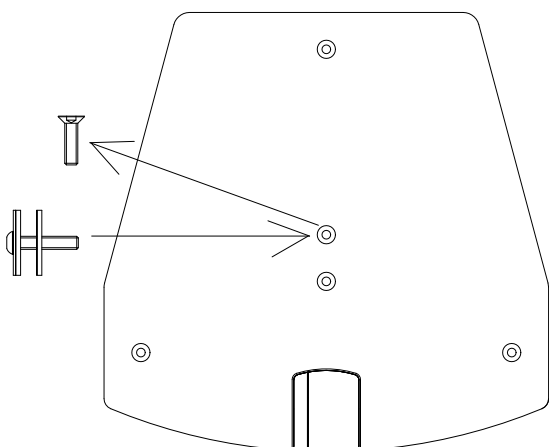

KEY12 / KEY12A

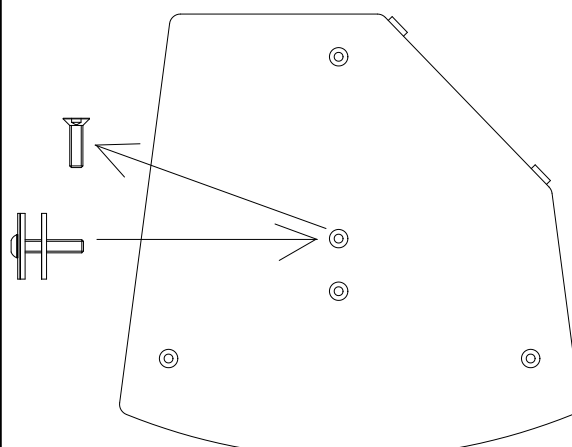

JK15 / JK15N / JK15A / JK15NA

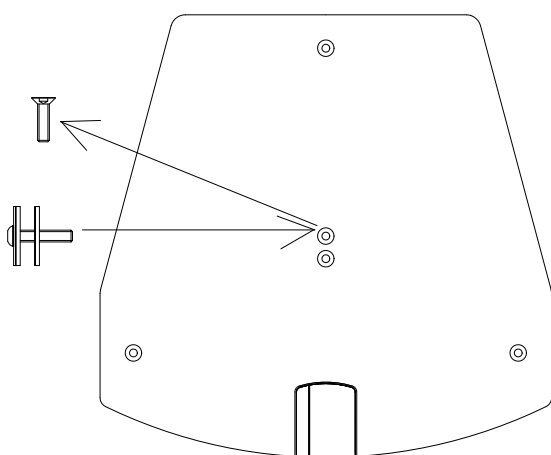

KEY15 / KEY15A

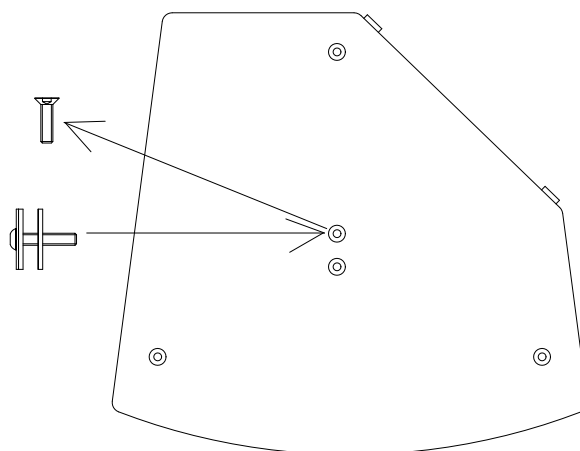

KEY8

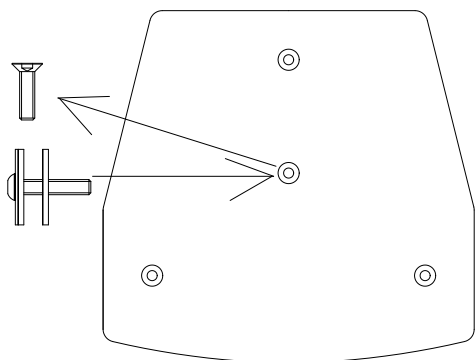

X15T / X15D

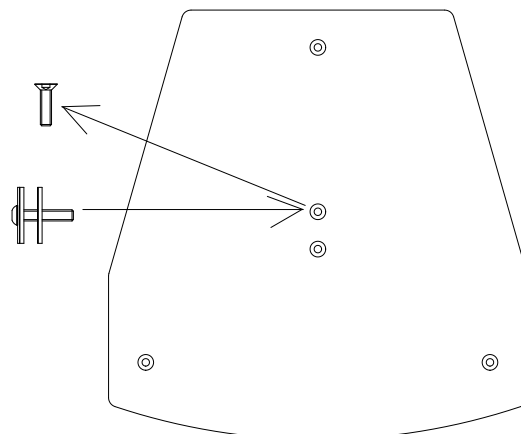

X14T

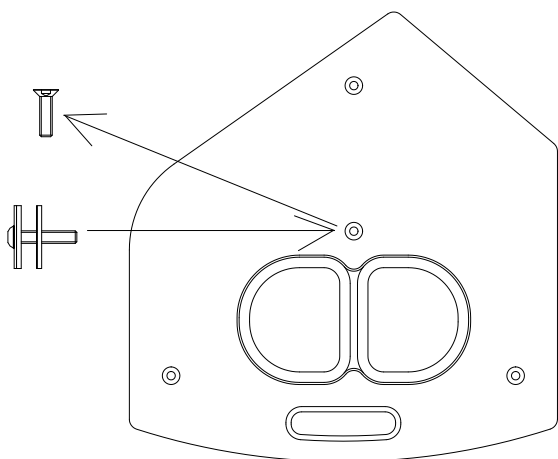

JK12MA

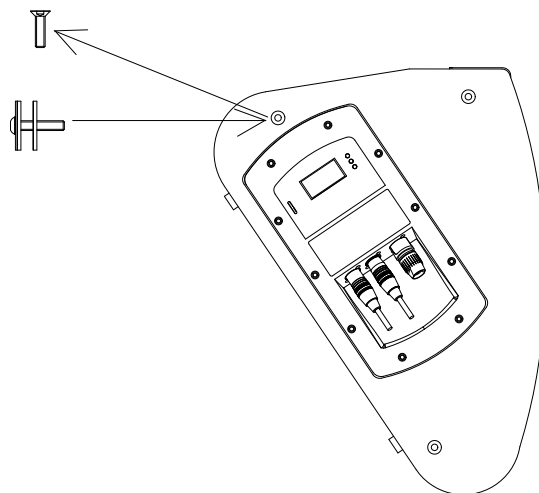

N26 / N26P

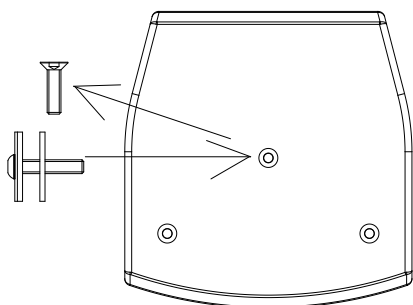

N10

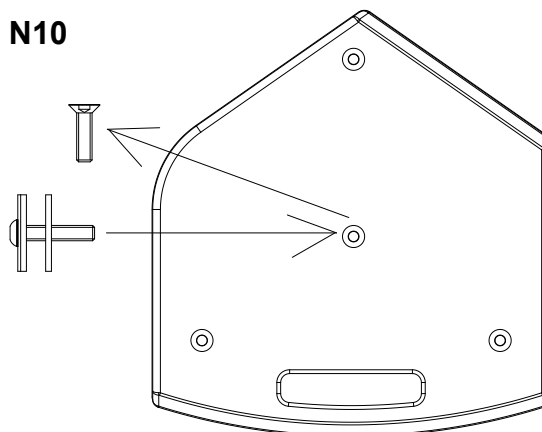

N12 / N12P / N12PR / N12P7 / N12A6

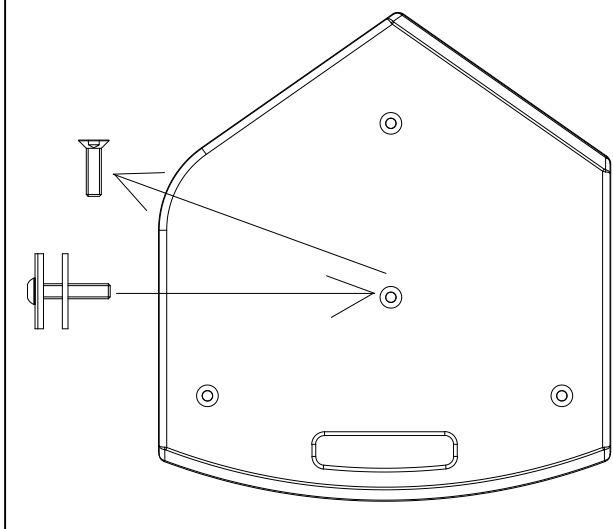

N15 / N15P / N15PR

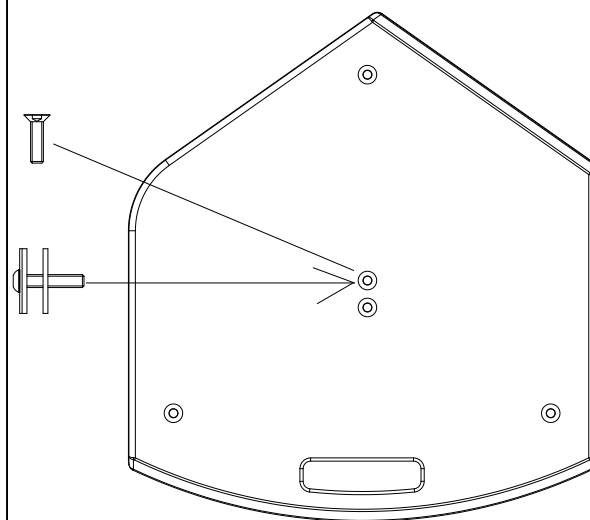

X14FD

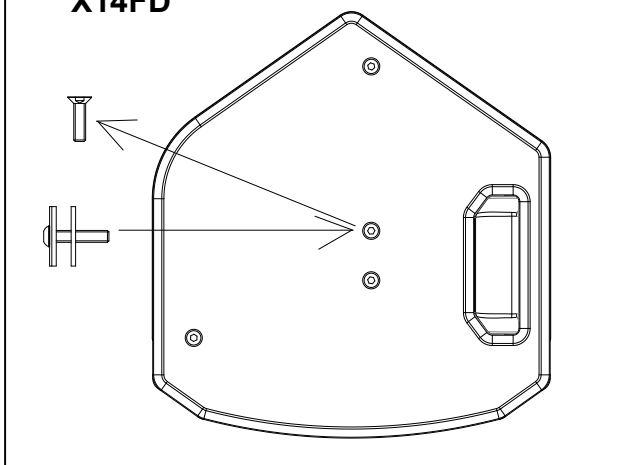

S26 / S26P

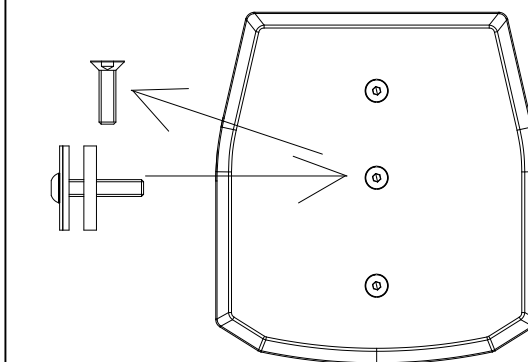

S12 / S12P

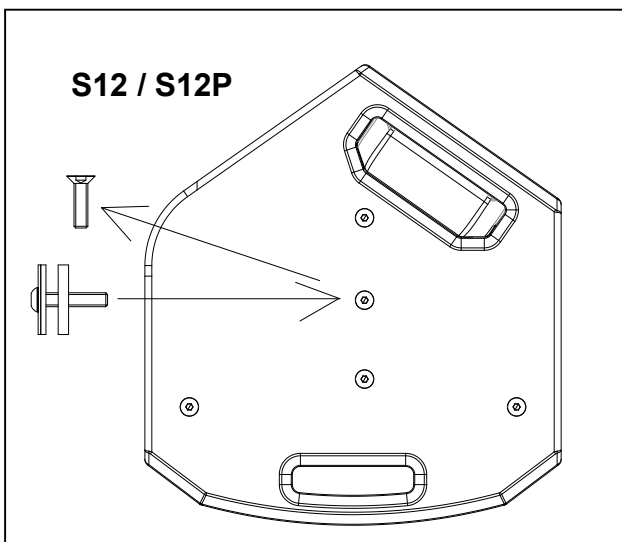

N10P

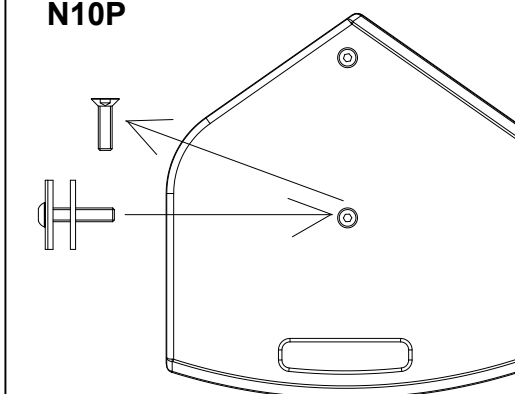

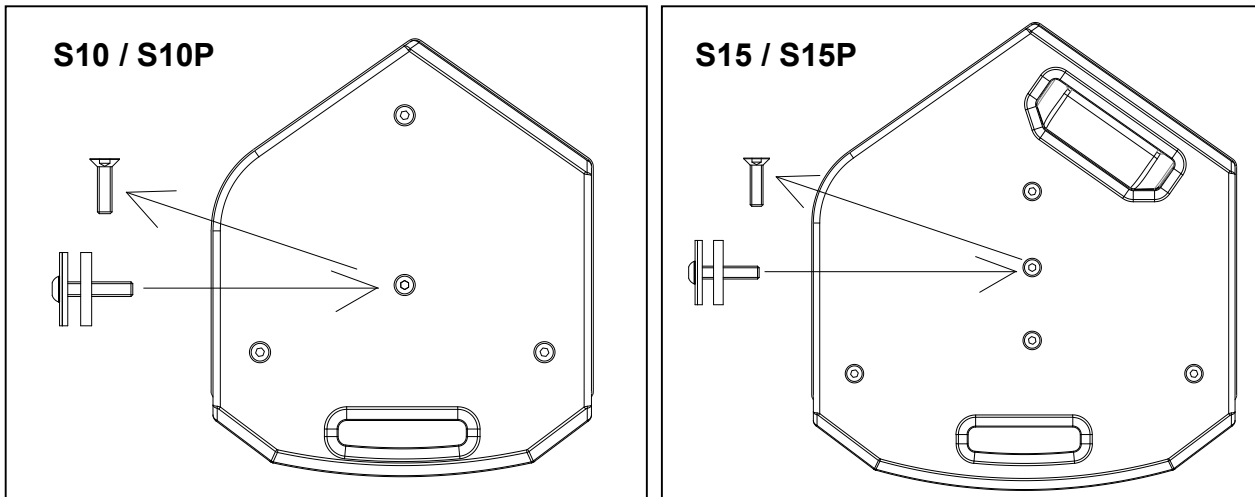

- Set the ACRM8 eyebolts on the cabinet's M8 (i.e.1 and 2 points) rigging points (only if you have the SC15 security kit)

~ Coloque la anillas ACRM8 en los puntos de fijación de la caja (por ejemplo los puntos 1 y 2 o dos puntos que le sean cómodos) para posteriormente, pasar la eslinga de seguridad (sólo en caso de disponer del "kit" opcional de seguridad SC15)

JK26 / JK26A+

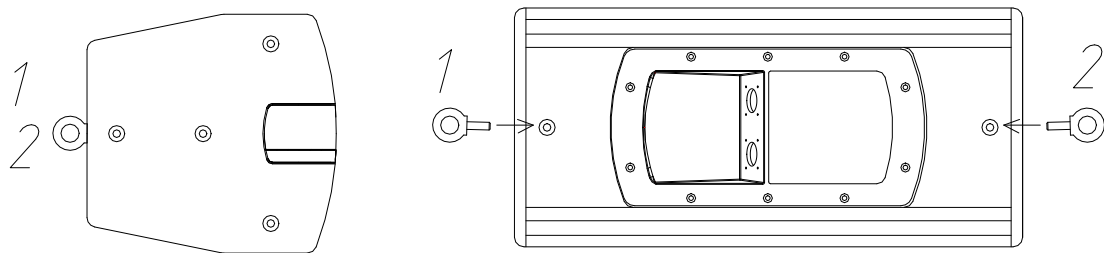

JK10 / JK10A

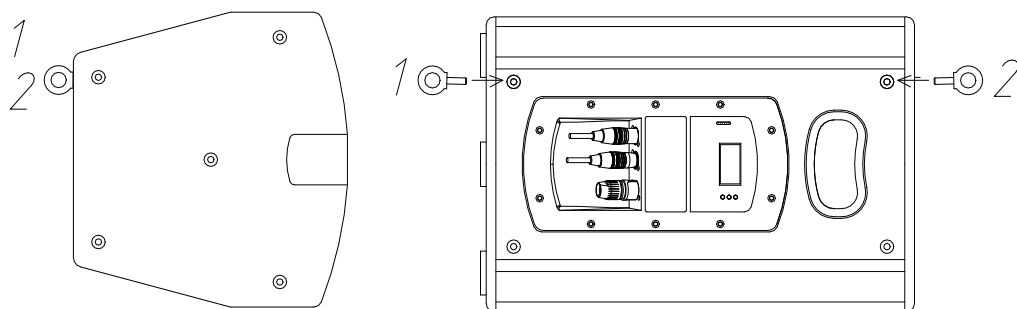

JK10MA

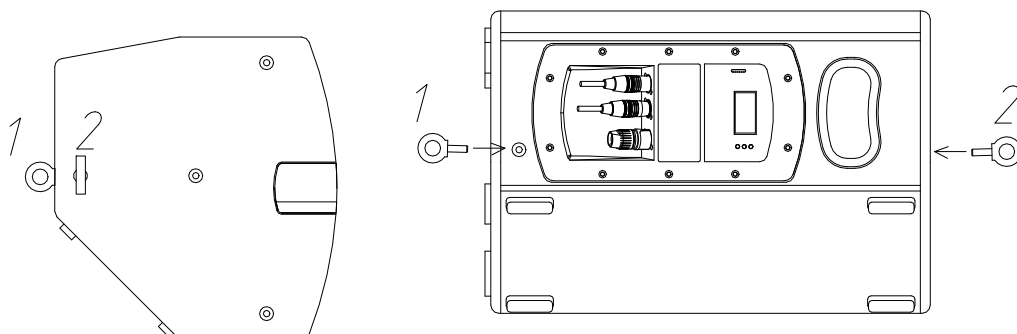

KEY10 / KEY10A

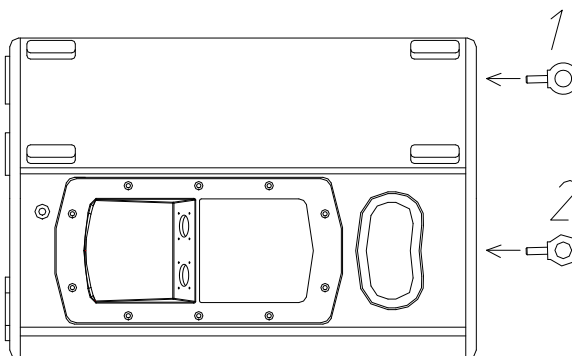
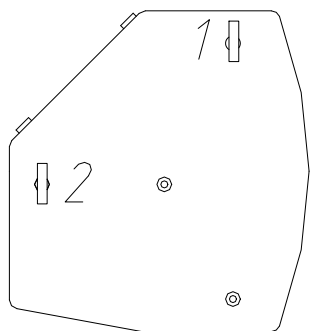

JK12 / JK12A

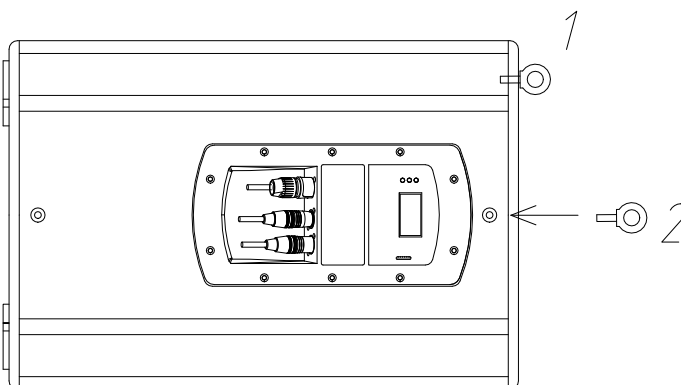
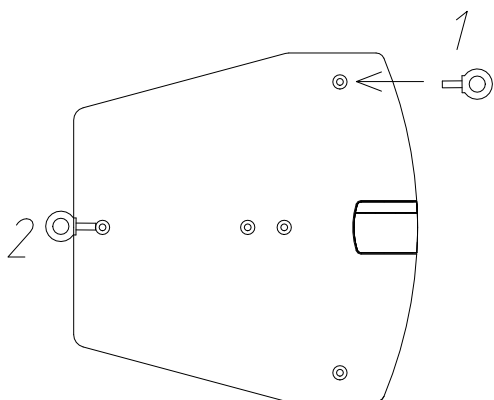

KEY12 / KEY12A

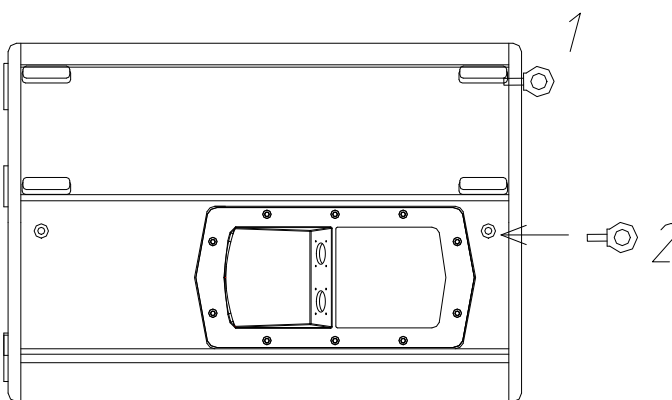
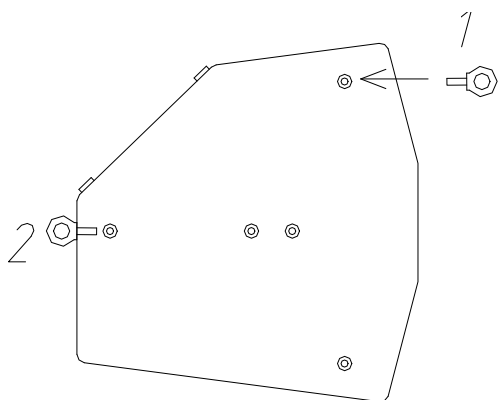

JK15 / JK15N / JK15A / JK15NA

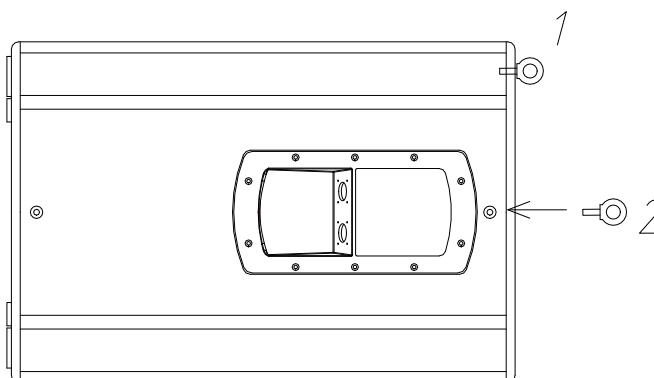
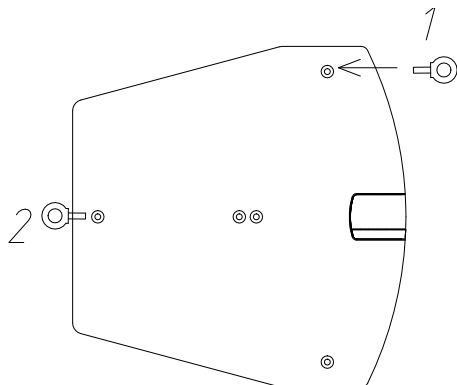

KEY15 / KEY15A

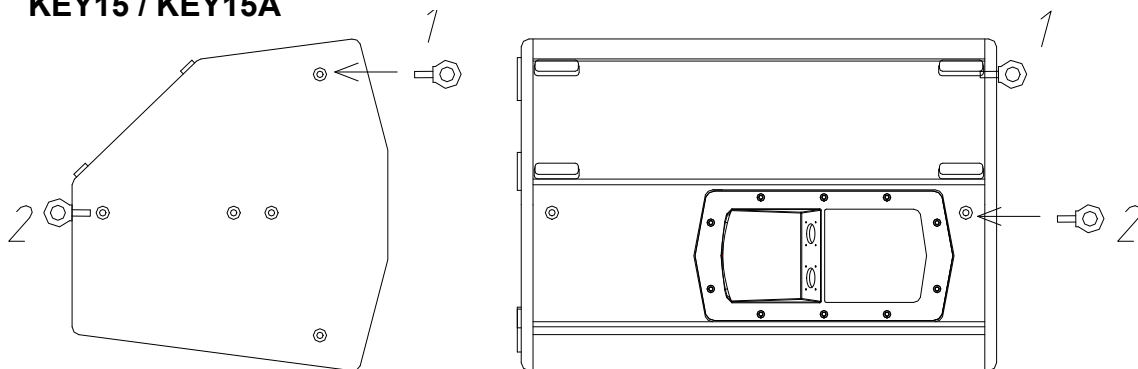

KEY8

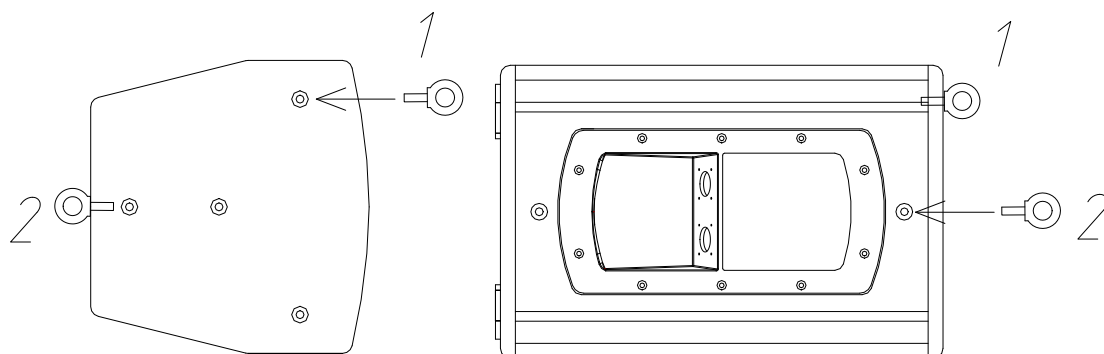

X15T / X15D

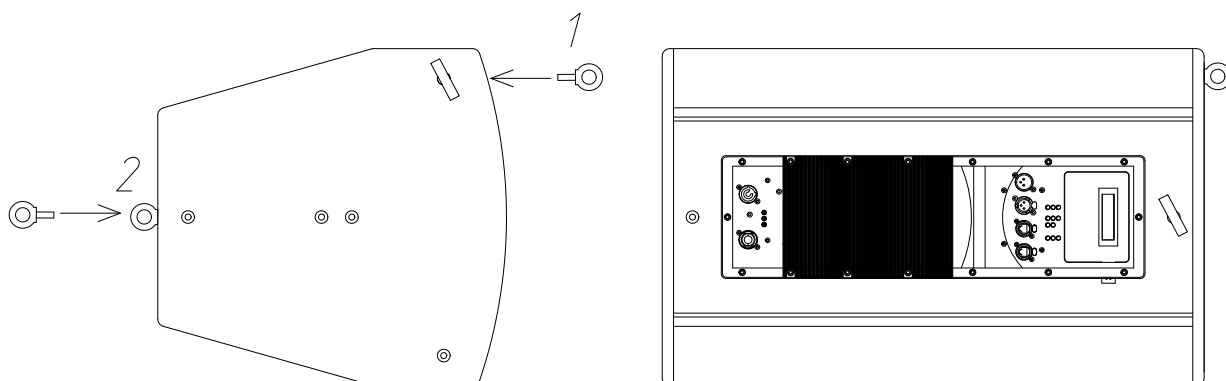

X14T

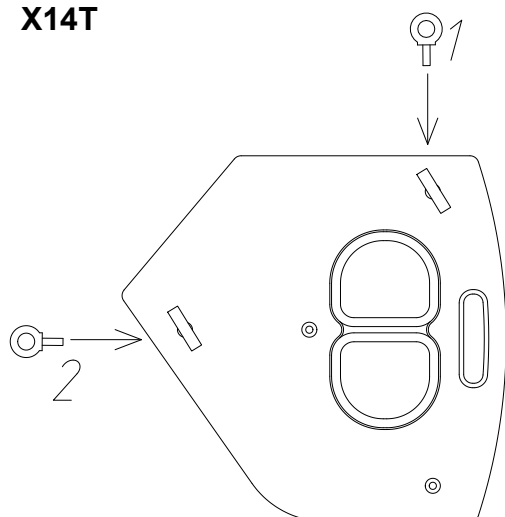

JK12MA

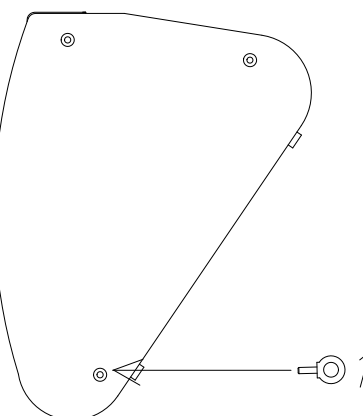

N26 / N26P

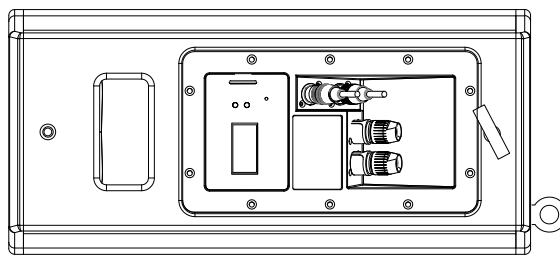
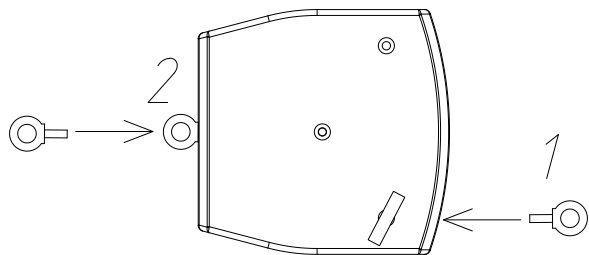

N10

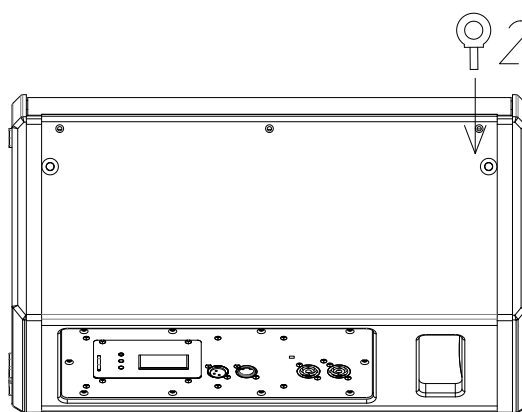
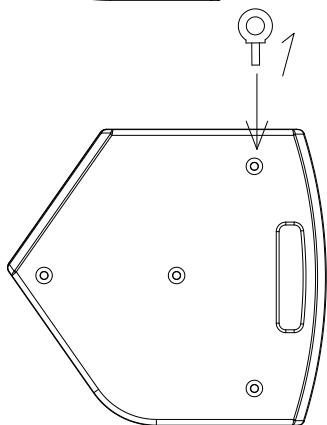

**N12 / N12P / N12PR
N12P7 / N12A6**

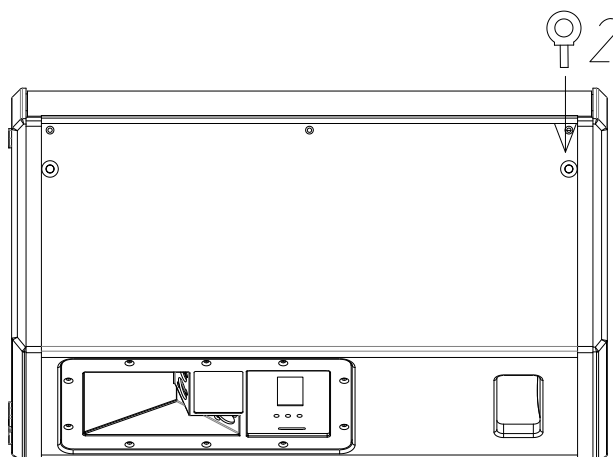
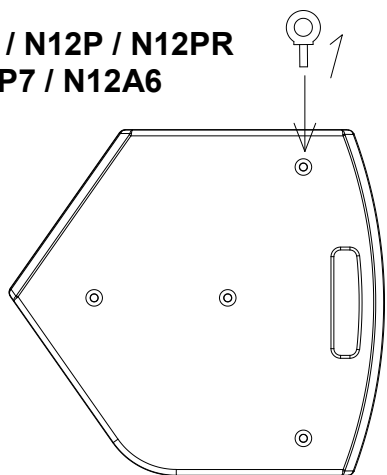

N15 / N15P / N15PR

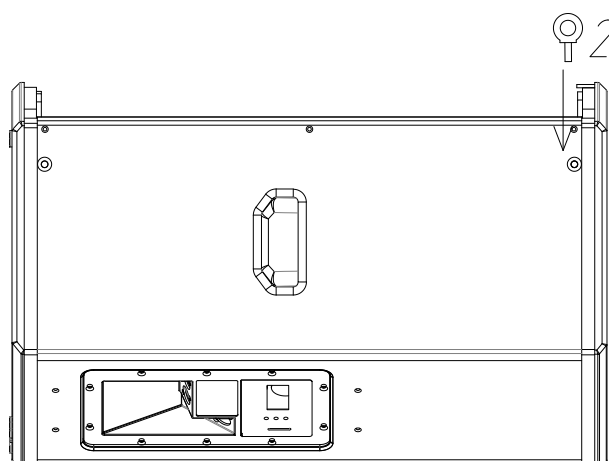
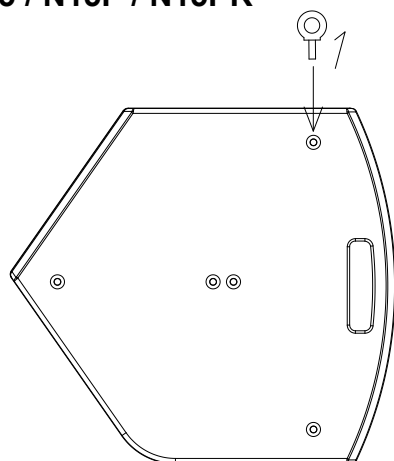

X14FD

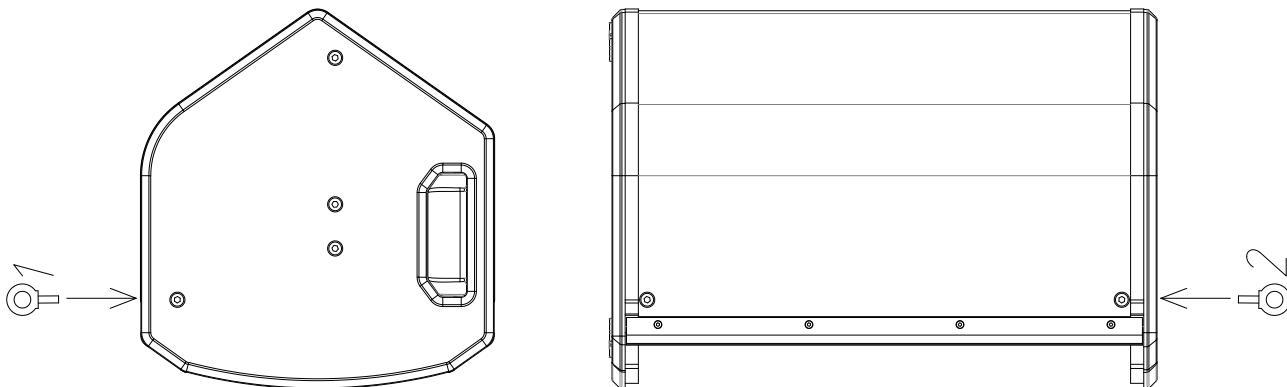

S26 / S26P

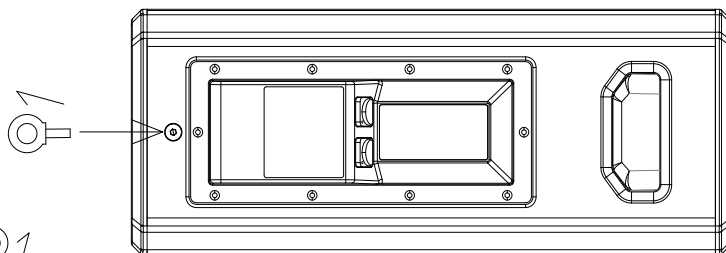

S12/ S12P

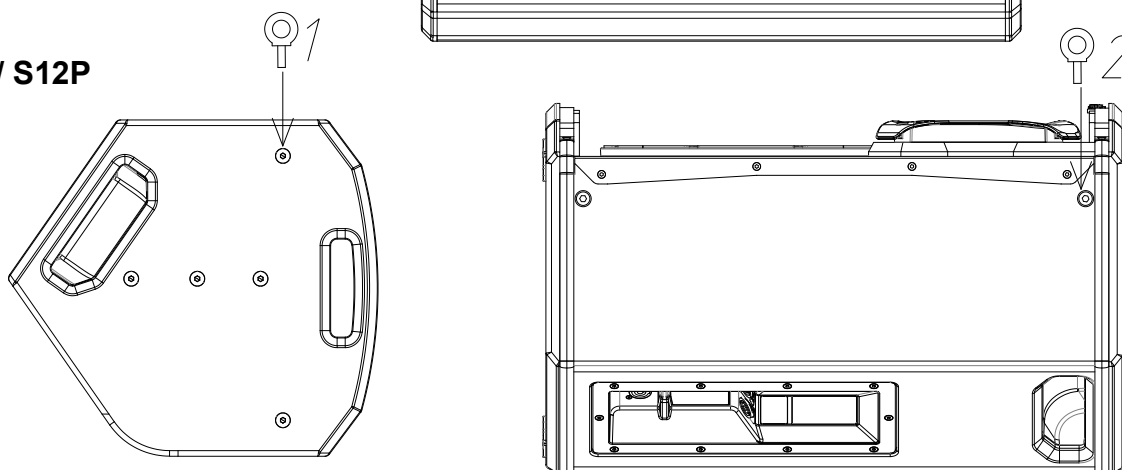

S10/ S10P

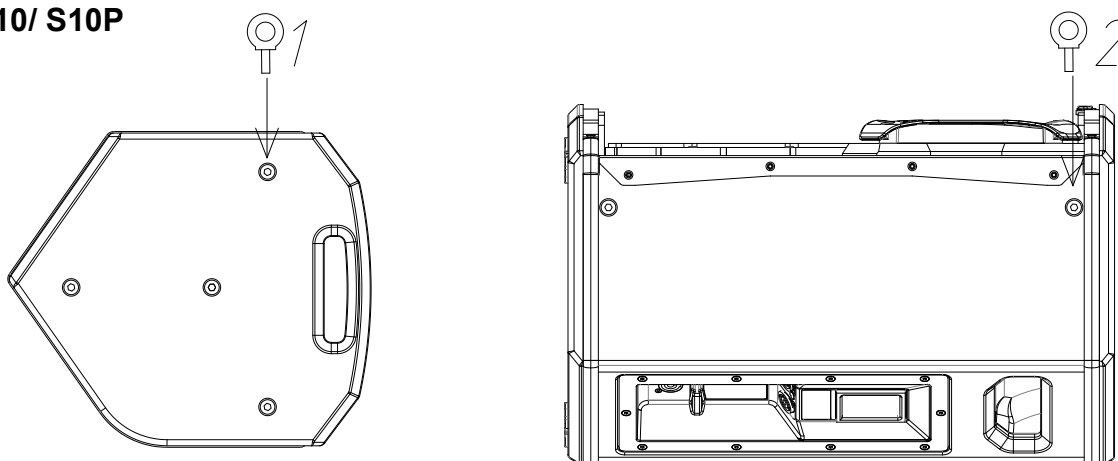

S15 / S15P

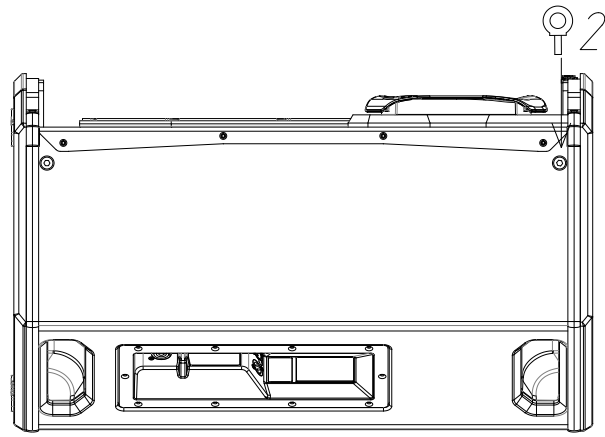
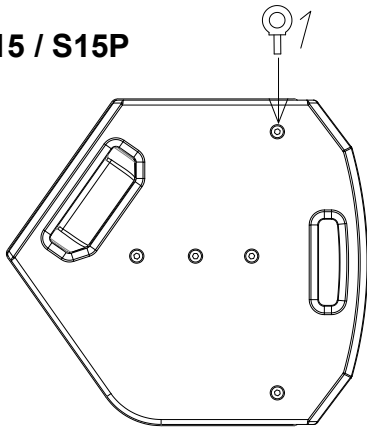

- Place the supplied template on the wall and mark the fixing points in the correct location, according to each model.
 ~ *Coloque la plantilla de papel en la pared y marque los puntos de fijación (dependiendo de cada modelo)*

KEY8 (463mm)

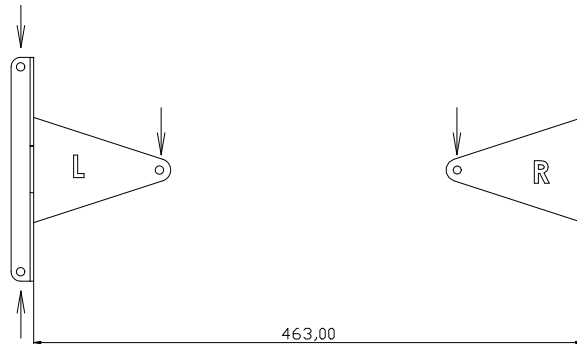

KEY10 / KEY10A / JK26 / JK26A+ / JK10 / JK10A / JK10MA (548mm)

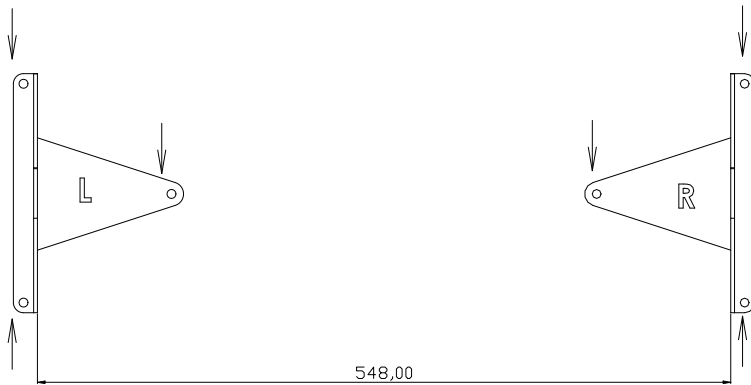

KEY12 / KEY12A / JK12 / JK12A / JK12MA (621mm)

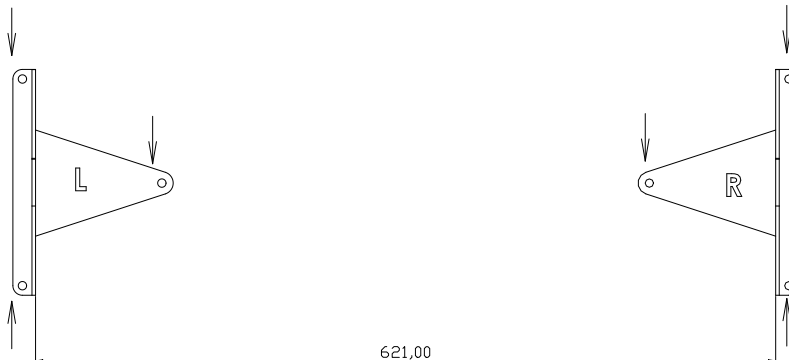

KEY15 / KEY15A / JK15 / JK15N / JK15A / JK15NA (701mm)

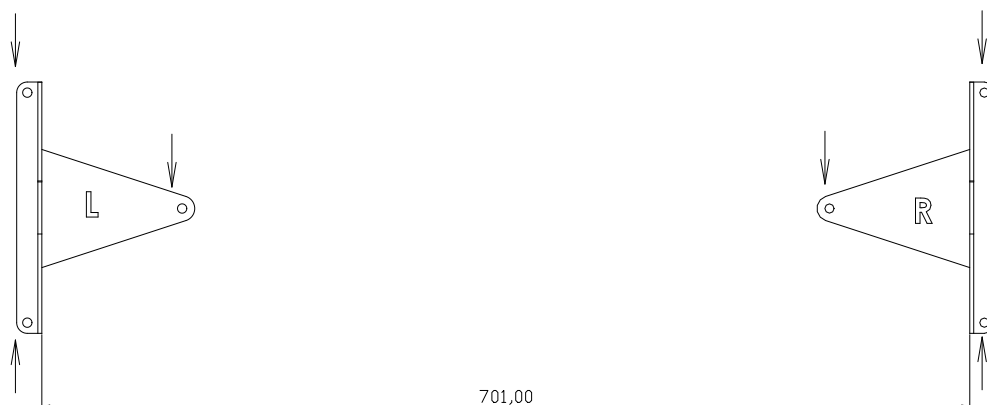

X15T/ X15D (733mm)

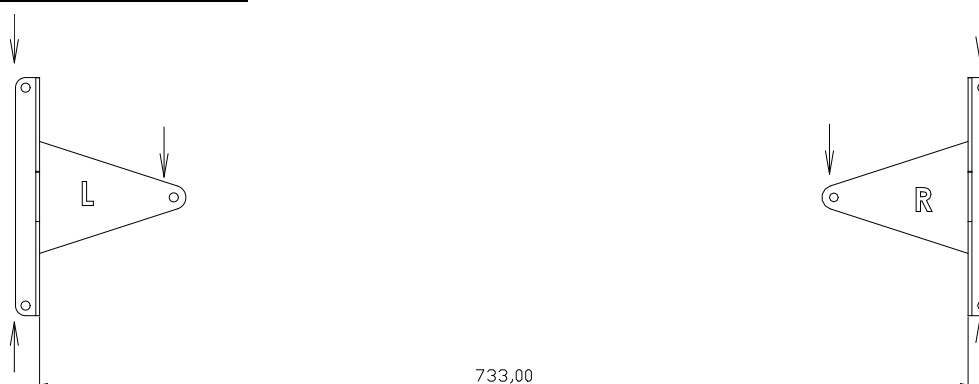

X14T / N12 / N12P / N12PR / N12P7 / N12A6 / X14FD / S12 / S12P (638mm)

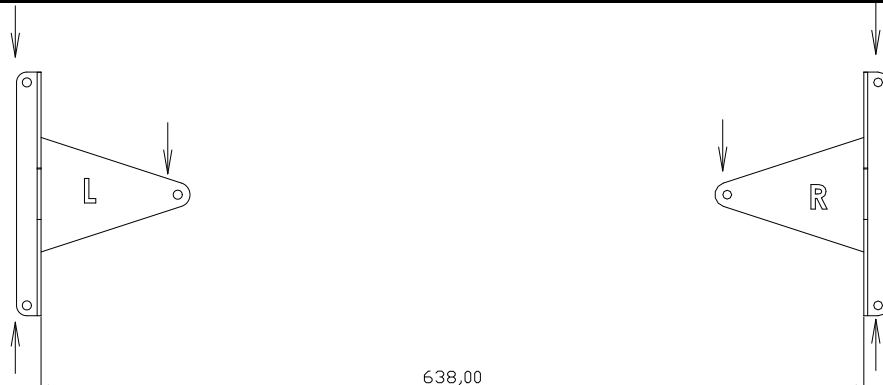

N26 / N26P (552mm)



N10 / N10P / S10 / S10P (558mm)

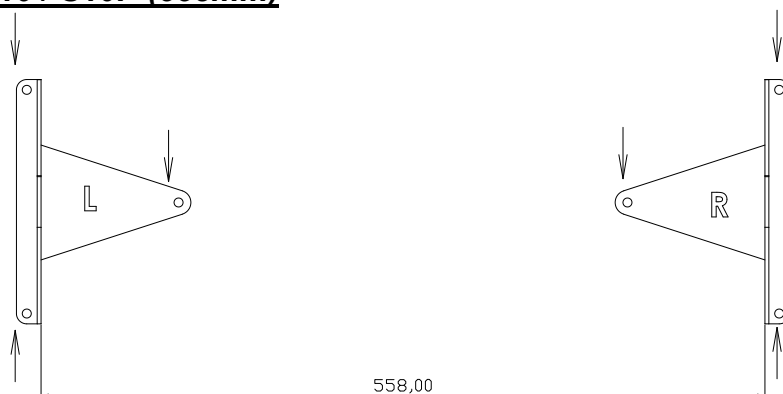

N15 / N15P / N15PR / S15 / S15P (748mm)

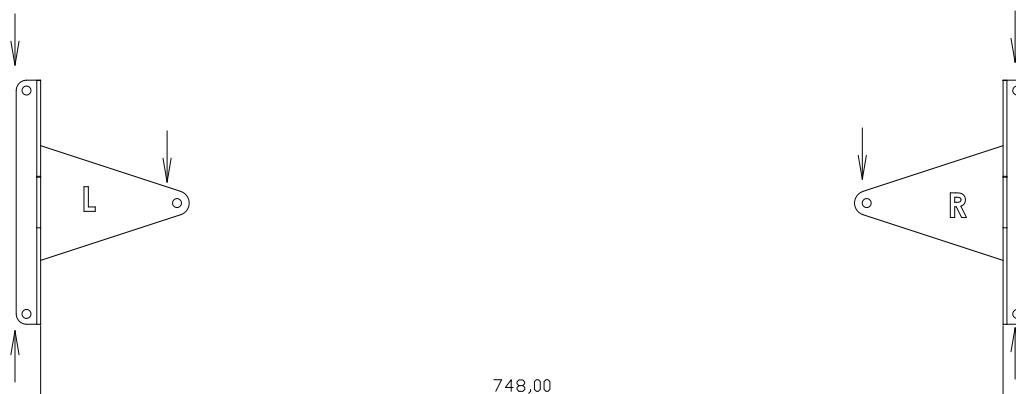

S26 / S26P (590mm)

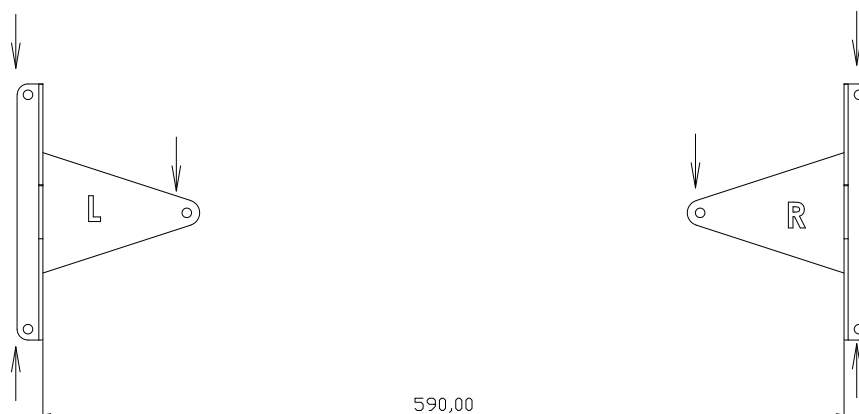

- Drill some corresponding pilot holes on the wall and fix the bracket using the wall plugs and the six DIN7505B 5x30 screws supplied in the kit
~ *Realice los taladros en la pared y cuelgue el soporte con tornillería adecuada y de alta resistencia (tacos M6 y tornillos DIN7505B 5x30 suministrados en el "kit")*
- Place the cabinet on the bracket and fix it with both M8 screws (1)
~ *Coloque la caja entre el soporte y la pared y fijela con los dos tornillos de M8 (1)*

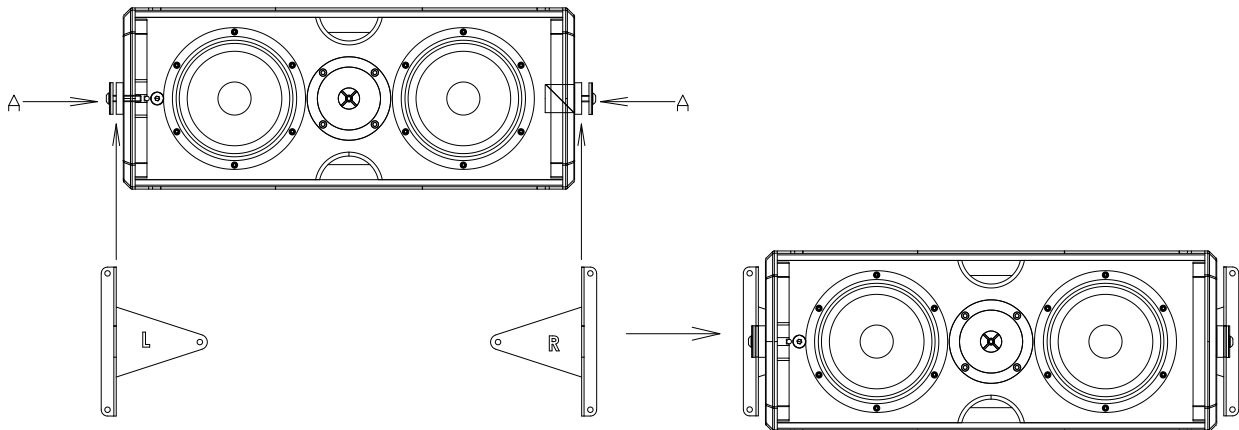

- **A: Metal washer 1.5mm**
~ *A: Arandela de metal 1,5mm*

- **B: Rubber washer 3mm**
~ *B: Arandela de goma 3mm*

- **C: UB-L bracket**
~ *C: Soporte UB-L*

- **D: Rubber washer 9mm**
~ *D: Arandela de goma 9mm*

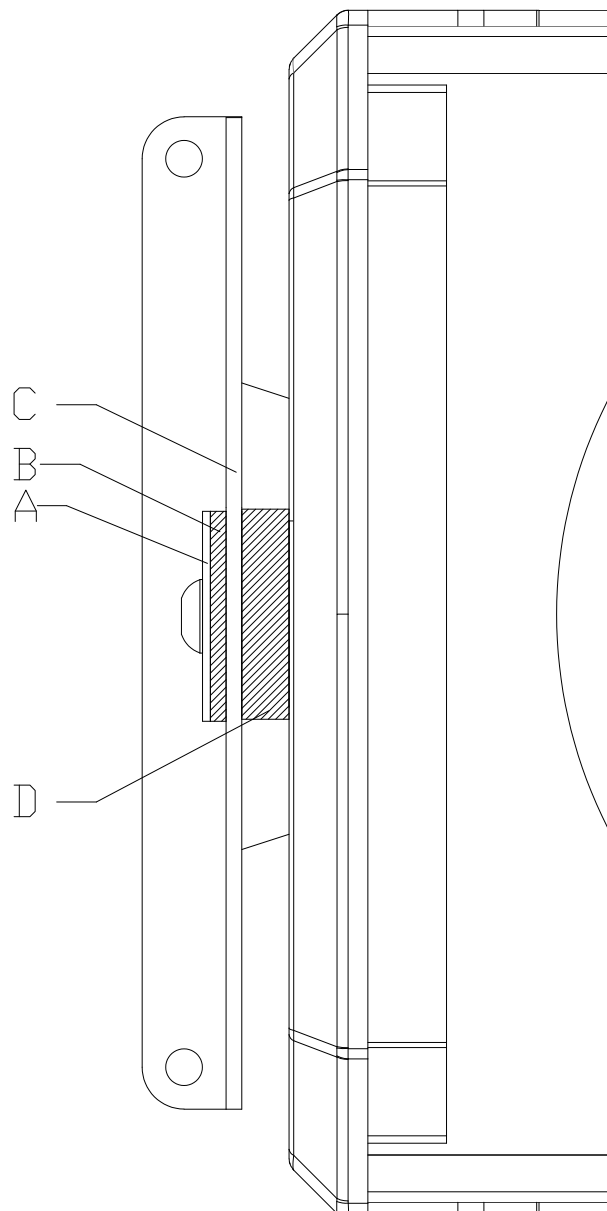

- Choose the desired tilt angle and block the cabinet with the M8 lateral screws. You can use the safety cable around the ACRM8 eyebolts. In this case, fix the safety cable on a secondary external point.

- ~ *Dar la inclinación necesaria y bloquear con los tornillos laterales de M8. Puede usar la eslinga como medida de seguridad adicional, colocándola por el interior de las anillas ACRM8. En este caso, la eslinga debe fijarse a un punto externo de carga.*

